



závěšová strana T



závěšová strana E5



závěšová strana A¹⁾



závěšová strana P



závěšová strana K

držák

stranové seřízení

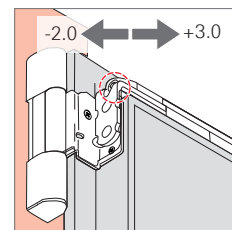
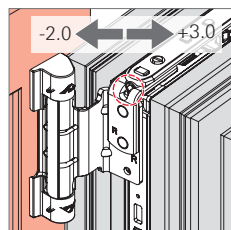
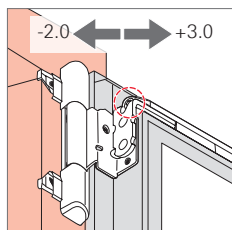
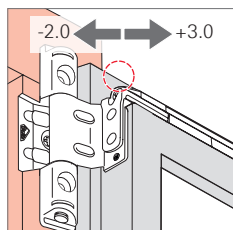
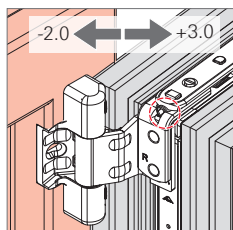

přítlak

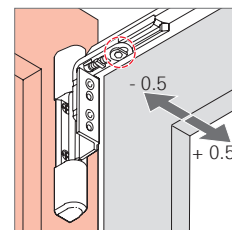
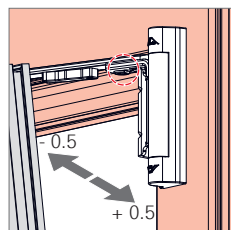
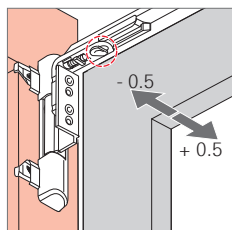
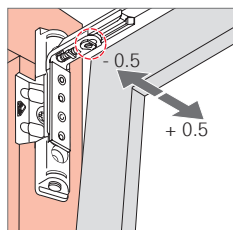
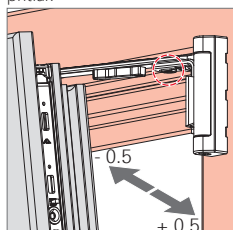

rámové ložisko

výškové a stranové seřízení

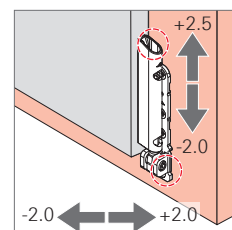
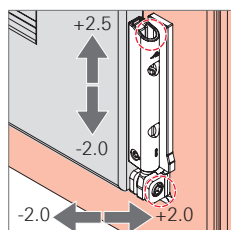
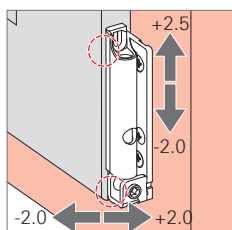
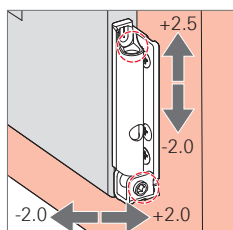
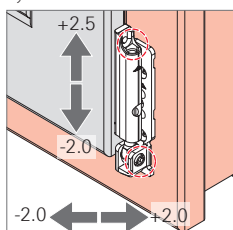

přítlak

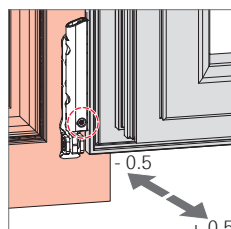
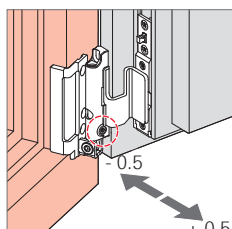
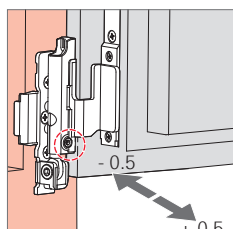
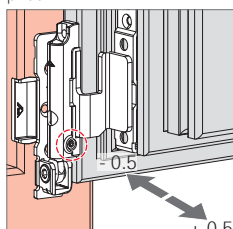

1) při použití krytek (držák / rámové ložisko) se mění uváděné hodnoty seřízení.



INFO

Roto Frank
Okenní a dveřní technologie GmbH













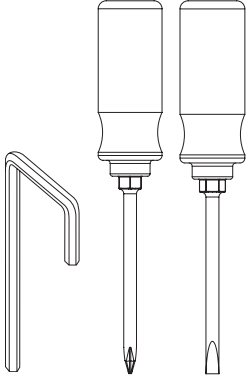



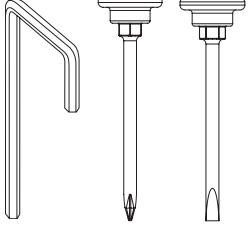

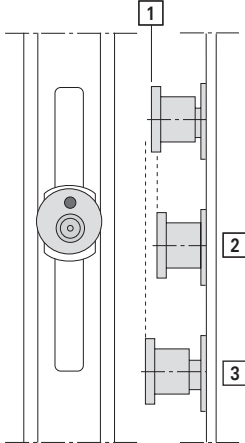
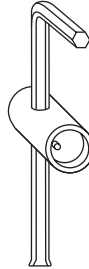

Výhradní zastoupení pro ČR:
R.T. kování a.s.

Kříčkova 373
592 31 Nové Město na Moravě
Telefon: +420 566 652 411
E-mail: nove.mesto@rtkovani.cz

Na Kuničkách 38
251 63 Kunice
Telefon: +420 323 619 081
E-mail: kunice@rtkovani.cz

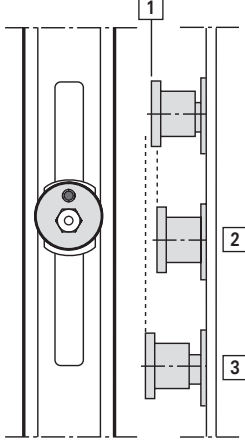
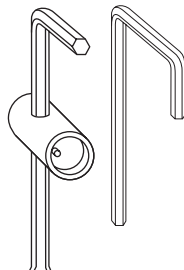
www.rtkovani.cz

Seřizovací nástroje		
Označení		Objednací číslo
	imbusový klíč: E- a P- závěrový čep 4mm	208609
	imbusový klíč: dodatečné seřízení (2,5/4mm)	230764
	seřizovací nástroj: V-čep	258191 381574

E-čep	Rozsah seřízení	Seřízení přitlaku	Výška	Boční pohled	Nástroj
					
		±0,8 mm			
P-čep	Rozsah seřízení	Seřízení přitlaku	Výška	Boční pohled	Nástroj
					
		±0,8 mm			
V-čep	Rozsah seřízení	Seřízení přitlaku	Výška	Boční pohled	Nástroj
			±0,8 mm	 [1] 0 = základní pozice [2] -0,8 mm max. seřízení [3] +0,8 mm max. seřízení	
		±0,8 mm	±0,2 mm		
			±0,4 mm		
		±0,8 mm	±0,6 mm		
			±0,8 mm		
V-čep (od 2020)	Rozsah seřízení	Seřízení přitlaku	Výška	Boční pohled	Nástroj
			+1,5 mm -0,8 mm	 [1] 0 = základní pozice [2] -0,8 mm max. seřízení [3] +1,5 mm max. seřízení	
		±0,8 mm	±0,125 mm		
			±0,25 mm		
		±0,8 mm	±0,375 mm		
			±0,5 mm		